



Creative Lighting made for Control4 Vibrant DALI/DMX Gateway Installation Guide



Supported models

- CRE-EDIDIO-10-1D - Digital Lighting Gateway, DALI 1 bus
- CRE-EDIDIO-10-1X - Digital Lighting Gateway, DMX 1 universe
- CRE-EDIDIO-10-2D - Digital Lighting Gateway, DALI 2 buses
- CRE-EDIDIO-10-2X - Digital Lighting Gateway, DMX 2 universes
- CRE-EDIDIO-10-1D-1X - Digital Lighting Gateway, 1 Dali bus, 1 DMX universe

Accessories

- CRE-SPLTR-V2-LTNG: DMX Splitter Repeater with added protection from lightning
- CRE-UBI-V2-PWR: DALI Power 21V DC (250 mA)
- HDR-60-24: 24V DC, 60W power supply
- CRE-ADDICT: ADDICT V3 for DALI, DMX commissioning, with RDM support and WiFi

Introduction

The eDIDIO S10 gateway is a modular, network-enabled, DIN rail mounted, DALI and DMX lighting controller. It supports up to two lines of control via DALI, DMX, or both. This model is specially configured to work with Control4.

Features

Modular control: Modular hardware allows for any combination of up to two (total) DALI and or DMX512-A outputs while still maintaining proper DMX512-A signal conditioning and DALI separation.

Custom Control4 protocol: The eDIDIO supports custom Control4 protocol that includes support for SDDP, TLS 1.2, and additional features.

Easy installation: DIN Mounted with plug-and-play connectors: a black 2-way for DC in, a 12-way for I/Os, 2 x 3-ways for data lines, and a 4-way for logic ground and IR. If the controller is moved or removed, the connectors can remain conveniently behind, leaving the existing wiring connected to the connectors.

Multi-line control: Any interface or trigger in the system can call a command over multiple connected lines.

Easy-to-use configuration: An easy-to-use interface through Composer provides quick configuration and commissioning.

Easy wiring and system verification: The gateway contains a function which turns on all channels, making it easy to verify wiring and perform troubleshooting. See *Troubleshooting*, below, for details.

Specifications

The specifications are described below.

Model Number	CRE-EDIDIO-10-1D, CRE-EDIDIO-10-1X, CRE-EDIDIO-10-2X, CRE-EDIDIO-10-1D-1X
Input voltage	24V DC
Battery backup	3V DC, CR2032
DC input polarity reversal	Immune
Overcurrent protection	Yes
Transient protection	Yes
OLED screen	128 x 64, organic LED
Dimensions (WxHxD)	2.8 x 3.5 x 4.1" (72 x 88 x 105 mm) excluding terminals 2.8 x 4.3 x 4.1" (72 x 108 x 105 mm) with terminals
Weight (approximate)	0.4 lb (170 g)
Meets or exceeds relevant standards	AS/NZS 61347.2.1; EN 55015 + A1; EN61547+A1. CE and C Tick, IEC/AU CISPR15

Warnings and considerations

IMPORTANT! Read all installation instructions before beginning; if not qualified, do not attempt installation. Contact a qualified electrician.

IMPORTANT! To reduce the risk of fire, electric shock, or injury to persons, pay close attention to this manual and stay within its guidelines when using this product. Save these instructions for future use.

IMPORTANT! Do not cover this product with paper surface coverings, fabrics, streamers, or other similar combustible materials.

IMPORTANT! This device is rated for indoor use in dry locations.

IMPORTANT! Do not secure this product or its cord with staples, nails, or like means that may damage the outer jacket or cord insulation.

IMPORTANT! Do not install in airtight tanks or enclosures of any kinds.

WARNING! These products may represent a possible shock or fire hazard if improperly installed or attached in any way. Products should be installed in accordance with these instructions, current electrical codes, and/or the current National Electric Code (NEC).

WARNING! To reduce the risk of fire, electric shock or injury to persons, make sure that the electrical power to the system is disconnected at the source prior to installation or any servicing.

WARNING! Turning off connected lights via DALI or DMX commands does not disconnect power to the fixtures.

WARNING! This device must be protected by a circuit breaker (20A max).

ATTENTION! Cet appareil doit être protégé par un disjoncteur (20A max.)

IMPORTANT! Snap One is NOT liable for any damage incurred with the misuse of this product.

IMPORTANT! Snap One does not guarantee the performance of any device in your environment. Customer assumes all risks, including any damage to snap one products, associated with (i) the type, load rating and quality of the device, or (ii) any use or installation not in accordance with the documentation furnished by snap one, either with the snap one product or at www.snapone.com.

Installing the gateway

Fasten the gateway onto a DIN rail.

Wiring the gateway

Refer to the wiring diagrams below to wire the gateway. The first diagram shows a DMX-only configuration. The second diagram shows DMX, DALI, and contact input configuration.

Connecting Power

The gateway requires a 24V DC (>100mA) source (HDR60-24 recommended). Connect power to the gateway input screw down terminals marked **DC IN +** and **DC IN -**. The cable must be less than 98 feet (30 meters) from the DC power supply to the gateway.

For DALI to work, an external DALI PSU must be present on each line (CRE-UBI-V2-PWR recommended).

DALI line connection

The DALI line wires are connected in the screw terminals at the top of the enclosure as shown below. You must not have two DALI line power supplies on the same DALI line. DALI Standard mandates no more than 2V DC voltage drop.

DMX512-A line connection

The DMX512-A line wires are connected in the screw terminals at the top of the enclosure as shown above.

WARNING! Do not confuse the DALI and DMX512-A lines. Connecting a DALI bus PSU to a DMX512-A line will cause irreversible damage.

Contact input connection

The inputs of the gateway allow for short, long, and latching presses by connecting the input pin source to a ground pin source. This means that any potential-free contact, such as a switch mech or relay device, that can connect two wires together may be used as an input device for the gateway.

The inputs 1 to 8 will show about 3V DC (in reference to the GND pin) when floating, allowing for easy testing via multimeter. I/Os 9 to 12 will initially show a higher dc voltage and decay down to 3V DC over time. A display option is also available using the keypad/menu to show the state of each input.

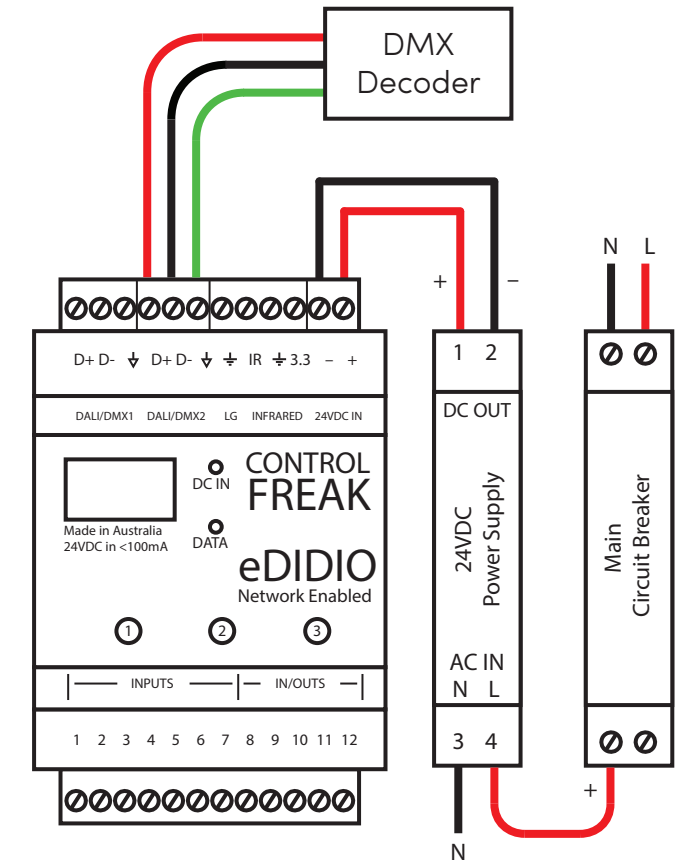

DMX decoder connections (model CRE-EDIDIO-10-1D-1X shown)

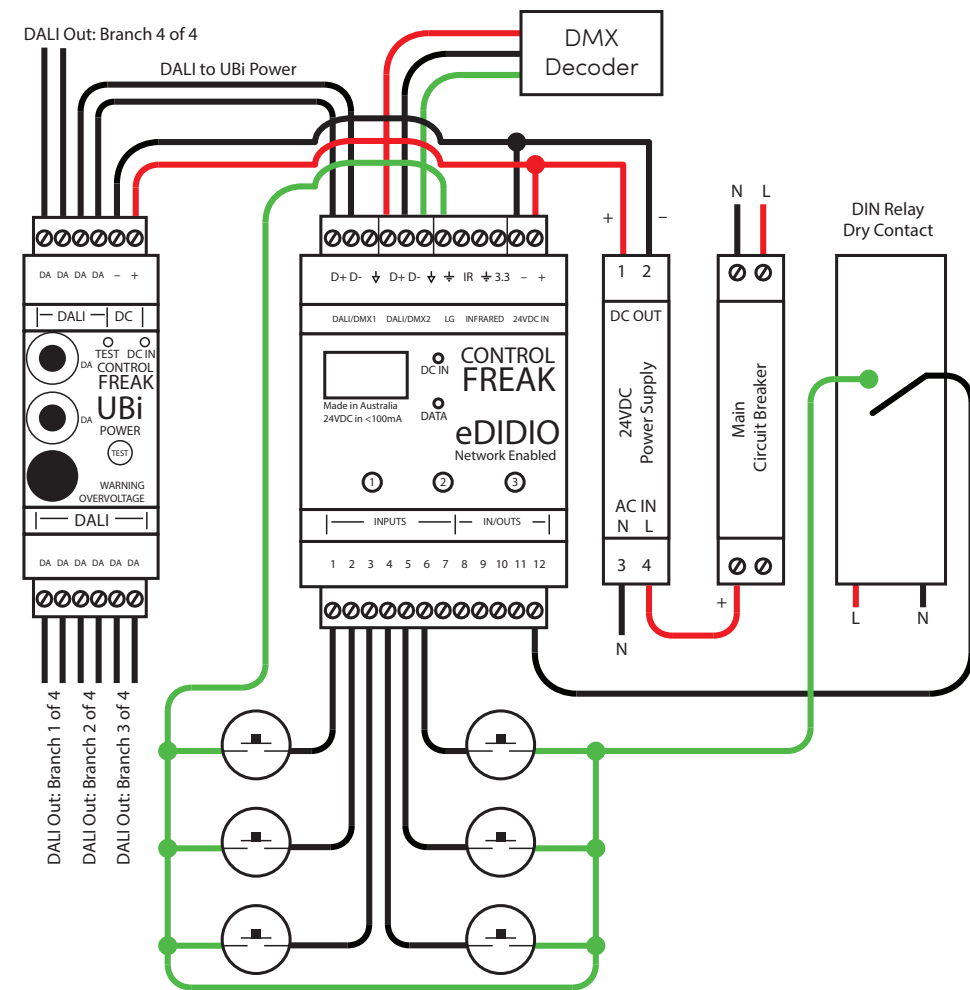

DMX decoder, DALI, and contact input connections (model CRE-EDIDIO-10-1D-1X shown)

Configuration with Composer Pro

We recommend that you take the Control4 Vibrant Linear Lighting Micro-Certification at <http://ctrl4.co/certification-vibrant>. It provides detailed explanations and video procedures for setting up DMX-controlled lighting.

Perform the following procedure to configure your DMX gateway and decoder in Composer Pro:

1. Open Composer Pro and connect to the project.
2. Add gateway drivers.
 - a. In the Items pane > Discovered tab > Manufacturer, find "CONTROL4FREAK" and double-click to add driver. Repeat this for each gateway in the project.
 - b. The gateway will reboot and may install updates. While updating, the driver will not respond. Do not remove power during this process.
 - c. You may track progress on the gateway's Properties tab. Give each gateway in the project a descriptive name.
3. Add DMX drivers.
 - a. For each zone of LED tape light, add one instance of the DMX light driver.
 - b. In the Items pane > Search tab, type "DMX Light", press **Enter**. Find and double-click "DMX Light Driver" to add.
 - c. Name the zone after the area it's illuminating (unless the customer has a preference).
4. Connect DMX Light drivers to the Lights
 - a. Click Connections > Control/AV tab. Select a gateway.
 - b. DMX devices have automatically connected to the first gateway added to the project.
 - i If there is more than one gateway in the project, reconnect the DMX devices to the correct gateways.
 - ii Select a gateway. From the Control Outputs pane, drag the output to the DMX device it will control. Do this for all gateways in the project.

Display

The gateway has a 128 x 96-pixel display that shows the time, status, and other useful information.

Home Screen

The home screen displays the time and date, as well as battery, temperature, and connection status icons. The battery icon appears when the PCB battery is below its recommended voltage, the temperature icon displays when over 50 degrees, and the connection status icon displays when a valid Ethernet connection is accepted.

An information line is available at the bottom of the display which provides status updates on schedules, burn-in, or current profile. The default is schedule status and is settable using the keypad menu.

Pressing any button opens the menu. With no user interaction after 10 seconds, the display automatically returns to the home screen.

Main Menu and 1, 2, 3 Buttons

The main menu shows options for Installation, Testing, and Settings. Button **1** moves the cursor up, button **3** moves the cursor down, and button **2** confirms selection.

Installation

The installation allows for random addressing of DALI fittings.

Testing

The testing screen allows for DALI and DMX512-A Min/Max commands, displaying of inputs, and counting devices. The Min/Max testing command is one of the best troubleshooting processes that you can use to test the DMX and DALI buses before commissioning and programming the system.

Settings

The settings screen lets you choose between various options, such as status information display and muting/unmuting sensors.

Troubleshooting

- Device not found by discovery: Check the connections and make sure the network symbol is present on the gateway OLED.
 - Using the keypad menu, check in Settings > Device Status to see if an IP has been set. If it is 0.0.0.0, check the router's network settings to make sure it supports DHCP.
- Device fails to select appropriate version: Reset power to the controller and make sure network is not affected by other devices.
- Startup system check: On startup, various systems are checked. They will display on the screen for 5 seconds after the standard boot sequence.
- To easily verify your wiring and system setup, press any button on the gateway. From the main menu, go down to Testing > Min/Max DMX or DALI (depending on the device). Press **2** to confirm. The lights will cycle full on and off. If your lights do not turn on, you may have a wiring problem.
- To return the gateway to factory defaults, perform the following:
 1. Press any button on the keypad to enter the menu.
 2. Navigate to Settings->Device->Factory Reset (1 = Up, 2 = Enter, 3 = Down)
 3. Enter the code: 2 8 7 5.
 4. The device resets to factory defaults and the lines are configured to match the inserted hardware (DALI/DMX).

Warranty and legal information

We want to make our Third-Party Partner program as easy as possible. That's why we process all claims directly, without any third party telephone tag. Contact Customer Service at [866.424.4489](tel:866.424.4489).

Find other legal resources, such as regulatory notices and patent information, at snapone.com/legal.