

## INSTALLATION MANUAL

Ultra White and Ultra Acoustiweave™ Thin-Bezel Fixed Projection Screens

### **IMPORTANT: BEFORE YOU BEGIN**

- To avoid staining or scratching the screen, wear the included gloves during installation. Wash your hands and clean the work area before starting.
- Do not use knives or sharp objects to open the packing boxes.
- To avoid a serious fire hazard, DO NOT install the screen over an electrical outlet or switch.



## Step 1. Unpack the Screen

Lay out all parts on a clean, flat surface. To prevent damage, do not unpack the screen material at this time.

**NOTE:** Quantities below may be greater than needed for assembly.

### Package Contents



Screen Frame & Frame Bezels  
(2 short, 2 long each)

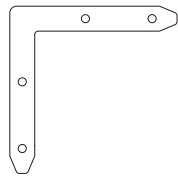

Corner Brackets  
(8)

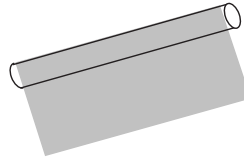

Screen  
Material (1)

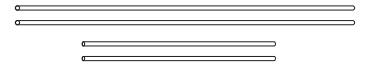

Tension Rods  
(2 short, 2 long each)

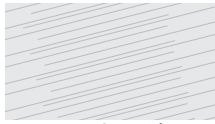

Protective Sheet  
(1)



Spring Tool (2)

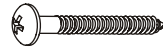

M5x50mm Phillips  
Head Screws (6)



Concrete  
Anchors (6)

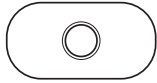

Sliding Nuts [*installed*]  
(14)



Material Springs  
[*installed*]  
\*Extra Springs included in the  
hardware pack (4)

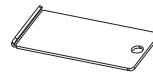

Thin Bezel Frame  
Brackets (10)



M5x6mm Corner  
Screws (46)



Gloves (2 Pair)



Mounting Brackets (2)  
Magnets (2)



M5x8mm Mounting  
Screws (4)



M5x8mm Magnet  
Mounting Screws (4)

## Step 2. Prepare Frame Sections for Assembly

A. Retention springs are pre-assembled. Please confirm based on quantity noted on frame label and in the manual below for the short and long frame sections and count all prior to install. Any extras needed are in the hardware pack.

Qty. of Pre-assembly Springs					
Screen Size	92"	100"	106"	110"	120"
Each Long Side	12	12	14	14	14
Each Short Side	7	7	8	8	9

i. The hook on the spring must be on the groove closest to the inside frame edge.

B. Sliding nuts are pre-installed into frames, 14 total. Sliding nuts are used to install the thin bezel caps, and wall brackets. **Please ensure all 14 sliding nuts are on the frames prior to installing and tightening the corner brackets.**

C. Install the corner brackets to the top and bottom slots of the short frame sections. All corner brackets are the same size and interchangeable.

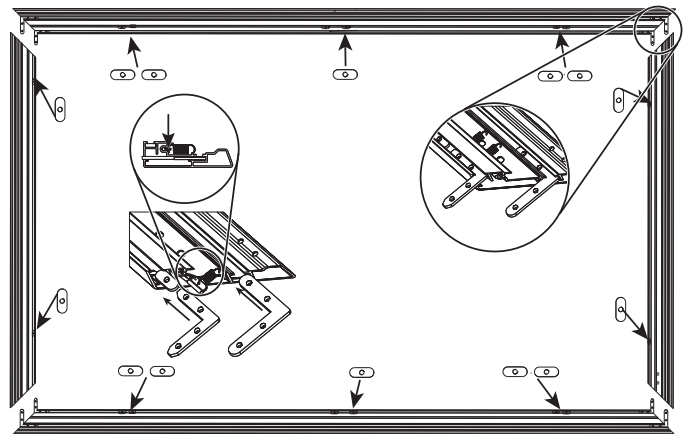

## Step 3. Assemble the Frame

- Slide the short frame sections into the long frame sections.
- Insert the 8 frame corner screws into all 4 corners of the frame and loosely tighten to hold the frame together.
- Hand-tighten all four screws, ensure the corners are square, then tighten the screws completely.
- Lift up and set aside to prepare screen material for assembly.

### Step 3

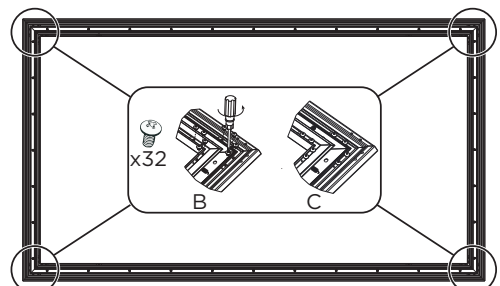

### Step 4. Prepare the Screen Material

- A. Lay the protective sheet out on the work surface, and clean the surface and work area to avoid staining the screen material.
- B. **Put on the supplied gloves before handling the screen material.**
- C. Roll the screen material out onto the protective sheet, then lay the frame down onto the material, ensuring the corners of the frame and fabric are properly aligned as shown in Step 4.
- D. Insert frame rods into the edges of the screen as shown in step 4.

#### Step 4

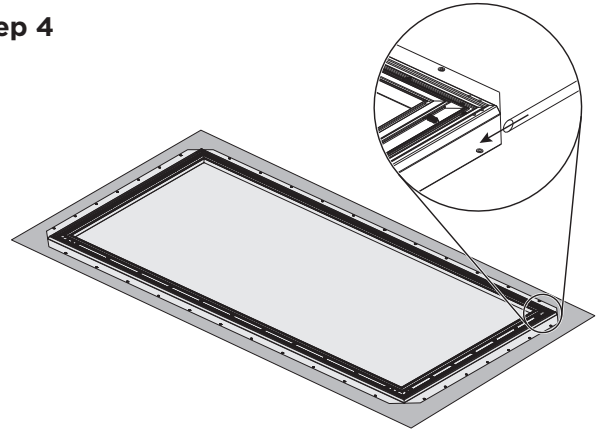

### Step 5. Attach the Screen Material to the Frame

- A. Align the springs to the holes in the screen fabric.
- B. Using the spring tool, attach the springs to the screen material, following the numbering in the image to the right, ensuring screen and frame stay aligned with corners. Once the corners are connected, work around the screen attaching the remaining springs.
- C. Ensure all springs are installed straight and perpendicular to the screen. Any springs installed at an angle may cause ripples in the screen material.

#### Step 5

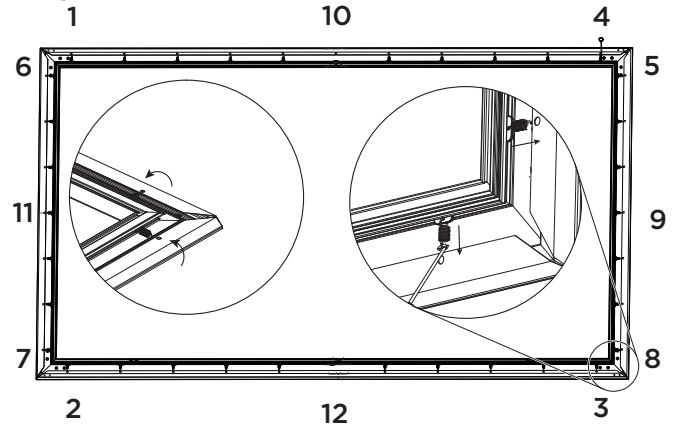

### Step 6. Install Brackets and Frame Bezels

- A. With the film screen still laying face down, lay the thin bezel caps on to the respective horizontal and vertical edges of the screen. The aluminum side should be facing up with fabric edges facing out. Refer to Image 6A.
  - i. The tracks on the back of the thin bezel caps align for a tight fit in each of the corners. Refer to image 6B.
- B. Once the thin bezel frames are in place and aligned, install the thin bezel frame brackets.
  - i. 10 total brackets will be used to tighten all 4 thin bezel caps in place. 2 brackets for each of the vertical frames and 3 brackets for each of the horizontal frames.
- C. Hook curved end of the thin bezel bracket to the outermost track of the thin bezel cap and align it with a sliding nut. Use the M5x6mm screws to tighten.

#### Step 6A

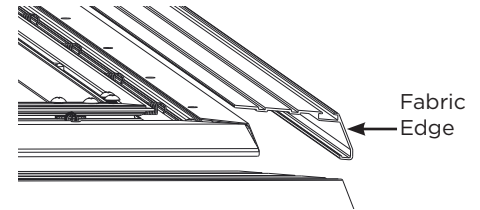

#### Step 6B-C

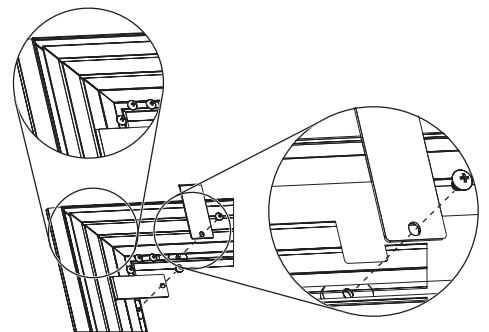

**Note:** There are 4 additional sliding nuts on the horizontal frames, 2 on each side. These sliding nuts are used to install the wall brackets.

#### Installation Tips

Take care to pull material evenly before installing the bezels. If waves/wrinkles are present, it may be necessary to remove the bezel and pull the material tightly before reattaching the bezel.

Refer to the image to the right for the best practice for smoothing wrinkles that may be present.

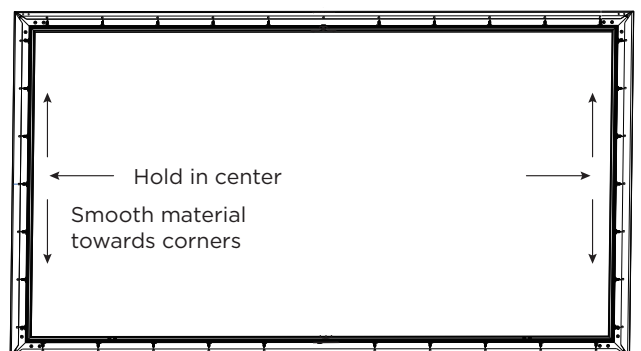

### Step 7. Attach and Install the Mounting Brackets

- A. Loosely secure the two mounting brackets to the sliding nuts in the top frame using the M5 x 8mm screws. The brackets should just be able to slide left and right.
- B. Loosely secure the circular metal half of the magnets to the lower frame, do not tighten the screws completely, the brackets should just be able to slide left and right.

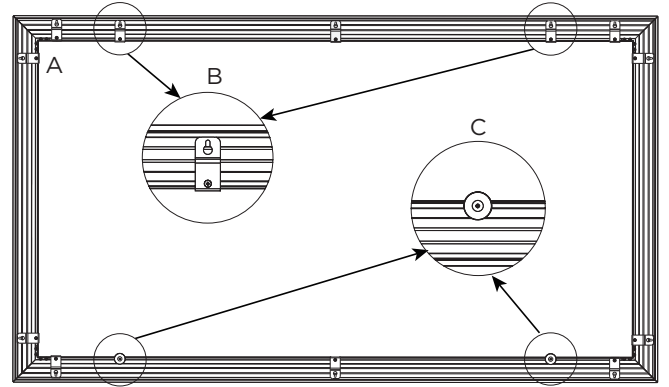

### Step 8. Hang the Screen

- A. Measure the overall Length and height of the screen frame.
- B. **For Drywall:** Drill 4 holes in the wall at the desired height. The distance of the horizontal holes should be about 2/3 the width of the frame, and the vertical distance of the holes should be the height of the frame minus 4 1/8" (105 mm).

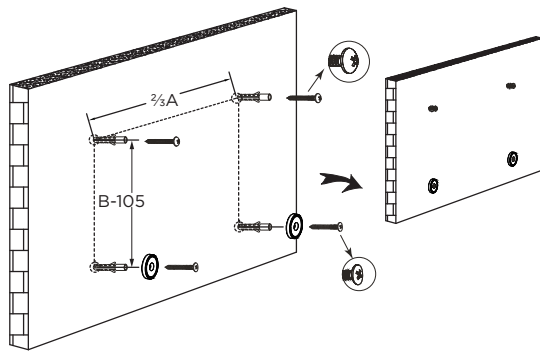

- C. **For Concrete:** Drive the concrete anchors into the holes drilled in Step B. Drive 2 M5x50mm Screws into the concrete anchors leaving 5mm to hang the screen. Install the lower 2 magnet pieces using 2 M5x50mm magnet screws. Hang the screen on the upper brackets and attach the lower part of the frame to the wall with the magnets.

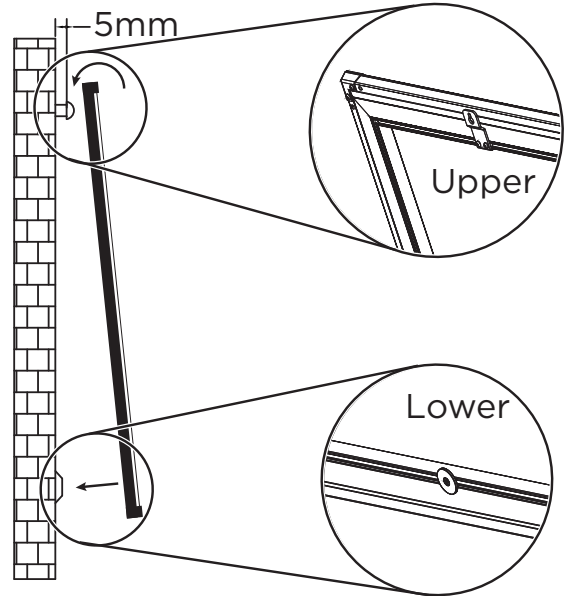

### Care and Cleaning

Clean the screen with a soft cloth using mild soap and water only. DO NOT use harsh detergents, chemicals, distilled spirits or petroleum-based chemicals to clean the screen. Doing so may result in severe damage to the screen or the frame coating.

Use a household vacuum cleaner with a brush or furniture cleaning attachment to clean the felt frame material. Avoid using excessive amounts of water on the felt.

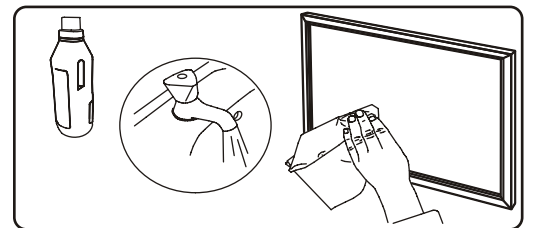

### Dimensions (in Inches)

A	B	C	D	E	F	G
92"	45.1	80.2	45.7	80.7	1.7	1.3
100"	49	87.2	49.6	87.7	1.7	1.3
106"	52	92.4	52.5	92.9	1.7	1.3
110"	53.9	95.9	54.5	96.4	1.7	1.3
120"	58.8	104.6	59.4	105.1	1.7	1.3

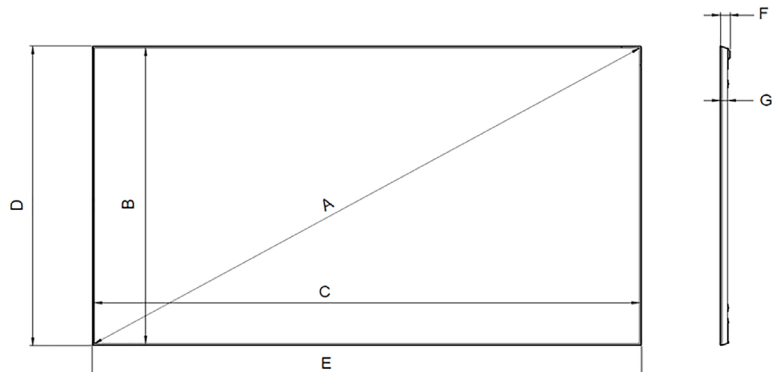

## Black Acoustically Transparent Material (Optional Installation)

Black acoustically transparent material is for the Acoustiweave™ screen only.

Light reflection may be a problem with any acoustically transparent material. If painting reflective surfaces to mitigate light reflection is not an option, hang the included black acoustically transparent material directly behind the screen using one of the following methods:

- Hot glue the black acoustically transparent material to the inside corners and mid-sections of the back of the frame.
- Carefully measure, then tack the black acoustically transparent material to the wall directly behind the screen.
- Unhook a tension spring from the screen fabric. Pierce the black acoustically transparent material with the spring and hook the spring back onto the screen. Start with the corners, then finish with the mid-sections.

## Warranty

Find details of this product's Lifetime Limited Warranty at [snapav.com/warranty](https://snapav.com/warranty), or request a paper copy from Customer Service at (866) 424-4489. Find other legal resources, such as regulatory notices and patent information, at [snapav.com/legal](https://snapav.com/legal).

## Technical Support

p.866.838.5052



Copyright ©2024, Wirepath Home Systems, LLC. All rights reserved. Control4 and Snap AV and their respective logos are registered trademarks or trademarks of Wirepath Home Systems, LLC, dba "Control4" and/or dba "SnapAV" in the United States and/or other countries. Dragonfly is also a registered trademark or trademark of Wirepath Home Systems, LLC. Other names and brands may be claimed as the property of their respective owners. All specifications subject to change without notice.

2024-08-08 MK